

## W265 / W285 FD HTST Divert Valves

WITH THE W-SERIES 2-PIECE CONTROL MODULE

FORM NO.: 95-03088 REVISION: 02/2020

READ AND UNDERSTAND THIS MANUAL PRIOR TO OPERATING OR SERVICING THIS PRODUCT.



Triplex Sales  
1-847-839-8442  
www.triplexsales.com

SPX FLOW, Inc.  
611 Sugar Creek Road  
Delavan, WI 53115 USA

Tel: (800) 252-5200 or (262) 728-1900  
Fax: (800) 252-5012 or (262) 728-4904

E-mail: [wcb@spxflow.com](mailto:wcb@spxflow.com)  
Web site: [www.spxflow.com](http://www.spxflow.com)

Information contained in this manual is subject to change without notice and does not represent a commitment on the part of SPX FLOW, Inc. No part of this manual may be reproduced or transmitted in any form or by any means, electronic or mechanical, including photocopying and recording, for any purpose, without the express written permission of SPX FLOW, Inc.

Copyright © 2020 SPX FLOW, Inc.

All Rights Reserved.

Tef-Flow is a trademark of SPX FLOW, Inc..

Revision Date: 02/2020



<b>Warranty</b> .....	<b>4</b>
Shipping Damage or Loss .....	4
Warranty Claim .....	4
<b>Safety</b> .....	<b>5</b>
<b>Care of Component Materials</b> .....	<b>6</b>
Stainless Steel Corrosion .....	6
Elastomer Seal Replacement Following Passivation .....	6
<b>Introduction</b> .....	<b>7</b>
Specifications .....	7
Features .....	7
<b>Installation</b> .....	<b>9</b>
Dimensions .....	9
Control Module Routing for Compressed Air, Vent and Wiring .....	10
Solenoids Operation .....	11
W265 / W285 Single Seat Solenoid and Port Arrangements .....	11
Control Module Wiring .....	12
<b>Operation</b> .....	<b>13</b>
Operating Modes .....	13
<b>Maintenance</b> .....	<b>16</b>
Maintenance Intervals .....	16
Inspection .....	16
Lubrication .....	16
Cleaning .....	16
Micro Switch .....	17
Lower Body Disassembly .....	18
Complete Disassembly .....	19
Removal and Installation of Tef-Flow™ P Seat Rings .....	22
<b>Inspection Test Procedures</b> .....	<b>23</b>
Test 1 - Device Assembled Correctly .....	23
Test 2 - Time Delay Interlock with Metering Pump .....	24
Test 3 - CIP Time Delay Relay .....	24
<b>Troubleshooting</b> .....	<b>25</b>
<b>Parts Lists</b> .....	<b>26</b>
W-Series 2 Piece Control Module with Micro Switches .....	26
W265 / W285 FD HTST Divert Valves .....	28
W265 / W285 4" and 5" Actuators .....	30
W265 / W285 6" Actuator .....	32
<b>Installation Tools</b> .....	<b>34</b>

## Warranty

LIMITED WARRANTY: Unless otherwise mutually agreed to in writing, (a) SPX FLOW US, LLC (SPX FLOW) goods, auxiliaries and parts thereof are warranted to the Buyer against defective workmanship and material for a period of twelve (12) months from date of installation or eighteen (18) months from date of delivery, whichever expires first, and (b) SPX FLOW services are warranted to Buyer to have been performed in a workman-like manner for a period of ninety (90) days from the date of performance. If the goods or services do not conform to the warranty stated above, then as Buyer's sole remedy, SPX FLOW shall, at SPX FLOW's option, either repair or replace the defective goods or re-perform defective services. If Buyer makes a warranty claim to SPX FLOW and no actual defect is subsequently found, Buyer shall reimburse SPX FLOW for all reasonable costs which SPX FLOW incurs in connection with the alleged defect. Third party goods furnished by SPX FLOW will be repaired or replaced as Buyer's sole remedy, but only to the extent provided in and honored by the original manufacturer's warranty. Unless otherwise agreed to in writing, SPX FLOW shall not be liable for breach of warranty or otherwise in any manner whatsoever for: (i) normal wear and tear; (ii) corrosion, abrasion or erosion; (iii) any good or services which, following delivery or performance by SPX FLOW, has been subjected to accident, abuse, misapplication, improper repair, alteration (including modifications or repairs by Buyer, the end customer or third parties other than SPX FLOW), improper installation or maintenance, neglect, or excessive operating conditions; (iv) defects resulting from Buyer's specifications or designs or those of Buyer's contractors or subcontractors other than SPX FLOW; or (v) defects resulting from the manufacture, distribution, promotion or sale of Buyer's products; (vi) damage resulting from the combination, operation or use with equipment, products, hardware, software, firmware, systems or data not provided by SPX FLOW, if such damage or harm would have been avoided in the absence of such combination, operation or use; or (vii) Buyer's use of the goods in any manner inconsistent with SPX FLOW's written materials regarding the use of such product. In addition, the foregoing warranty shall not include any labor, dismantling, re-installation, transportation or access costs, or other expense associated with the repair or replacement of SPX FLOW goods. THE WARRANTIES CONTAINED HEREIN ARE THE SOLE AND EXCLUSIVE WARRANTIES AVAILABLE TO BUYER AND SPX FLOW HEREBY DISCLAIMS ANY OTHER WARRANTIES, EXPRESS OR IMPLIED, INCLUDING WITHOUT LIMITATION THE IMPLIED WARRANTIES OF MERCHANTABILITY AND FITNESS FOR A PARTICULAR PURPOSE, ANY PERFORMANCE OR PROCESS OUTCOME DESIRED BY THE BUYER AND NOT SPECIFICALLY AGREED TO BY SPX FLOW. THE FOREGOING REPAIR, REPLACEMENT AND REPERFORMANCE OBLIGATIONS STATE SPX FLOW'S ENTIRE AND EXCLUSIVE LIABILITY AND BUYER'S EXCLUSIVE REMEDY FOR ANY CLAIM IN CONNECTION WITH THE SALE AND FURNISHING OF SERVICES, GOODS OR PARTS, THEIR DESIGN, SUITABILITY FOR USE, INSTALLATION OR OPERATIONS.

## Shipping Damage or Loss

If equipment is damaged or lost in transit, file a claim at once with the delivering carrier. The carrier has a signed Bill of Lading acknowledging that the shipment has been received from SPX FLOW in good condition. SPX FLOW is not responsible for the collection of claims or replacement of materials due to transit shortage or damages.

## Warranty Claim

Warranty claims must have a **Returned Material Authorization (RMA)** from the Seller or returns will not be accepted. Contact 800-252-5200 or 262-728-1900.

Claims for shortages or other errors must be made in writing to Seller within ten (10) days after delivery. This does not include transit shortage or damages. Failure to give such notice shall constitute acceptance and waiver of all such claims by Buyer.

## Safety

### READ AND UNDERSTAND THIS MANUAL PRIOR TO INSTALLING, OPERATING, OR SERVICING THIS EQUIPMENT

SPX FLOW recommends users of our equipment and designs follow the latest Industrial Safety Standards. At a minimum, these should include the industrial safety requirements established by:

1. Occupational Safety and Health Administration (OSHA)
2. National Fire Protection Association (NFPA)
3. National Electrical Code (NEC)
4. American National Standards Institute (ANSI)

#### **⚠ WARNING**

*Severe injury or death can result from electrical shock, burn, or unintended actuation of equipment. Recommended practice is to disconnect and lockout industrial equipment from power sources, and release stored energy, if present. Refer to the National Fire Protection Association Standard No. NFPA70E, Part II and (as applicable) OSHA rules for Control of Hazardous Energy Sources (Lockout-Tagout) and OSHA Electrical Safety Related Work Practices, including procedural requirements for:*

- Lockout-tagout
- Personnel qualifications and training requirements
- When it is not feasible to de-energize and lockout-tagout electrical circuits and equipment before working on or near exposed circuit parts

Before putting SPX FLOW equipment into operation, the operator shall analyze the application for all foreseeable risks, their likelihood to occur and the potential consequences of the identified risks as per ISO 31000 and ISO/IEC 31010 in their actual current version.

**Locking and Interlocking Devices:** These devices should be checked for proper working condition and capability of performing their intended functions. Make replacements only with the original equipment manufacturer's OEM renewal parts or kits. Adjust or repair in accordance with the manufacturer's instructions.

**Periodic Inspection:** Equipment should be inspected periodically. Inspection intervals should be based on environmental and operating conditions and adjusted as indicated by experience. At a minimum, an initial inspection within 3 to 4 months after installation is recommended. Inspection of the electrical control systems should meet the recommendations as specified in the National Electrical Manufacturers Association (NEMA) Standard No. ICS 1.3, Preventative Maintenance of Industrial Control and Systems Equipment, for the general guidelines for setting-up a periodic maintenance program.

**Replacement Equipment:** Use only replacement parts and devices recommended by the manufacturer to maintain the integrity of the equipment. Make sure the parts are properly matched to the equipment series, model, serial number, and revision level of the equipment.

Warnings and cautions are provided in this manual to help avoid serious injury and/or possible damage to equipment:

#### **⚠ DANGER**

*Immediate hazards which WILL result in severe personal injury or death.*

#### **⚠ WARNING**

*Hazards or unsafe practices which COULD result in severe personal injury or death.*

#### **⚠ CAUTION**

*Hazards or unsafe practices which COULD result in minor personal injury or product or property damage.*

## Care of Component Materials

**NOTE:** SPX FLOW recommends the use of an FDA-approved anti-seize compound on all threaded connections.

### **⚠ WARNING**

Failure to comply with the Care of Component Materials could lead to bodily injury.

### **Stainless Steel Corrosion**

Corrosion resistance is greatest when a layer of oxide film is formed on the surface of stainless steel. If film is disturbed or destroyed, stainless steel becomes much less resistant to corrosion and may rust, pit or crack.

Corrosion pitting, rusting and stress cracks may occur due to chemical attack. Use only cleaning chemicals specified by a reputable chemical manufacturer for use with stainless steel. Do not use excessive concentrations, temperatures or exposure times. Avoid contact with highly corrosive acids such as hydrofluoric, hydrochloric or sulfuric. Also avoid prolonged contact with chloride-containing chemicals, especially in presence of acid. If chlorine-based sanitizers are used, such as sodium hypochlorite (bleach), do not exceed concentrations of 150 ppm available chlorine, do not exceed contact time of 20 minutes, and do not exceed temperatures of 104°F (40°C).

Corrosion discoloration, deposits or pitting may occur under product deposits or under gaskets. Keep surfaces clean, including those under gaskets or in grooves or tight corners. Clean immediately after use. Do not allow equipment to set idle, exposed to air with accumulated foreign material on the surface.

Corrosion pitting may occur when stray electrical currents come in contact with moist stainless steel. Ensure all electrical devices connected to the equipment are correctly grounded.

### **Elastomer Seal Replacement Following Passivation**

Passivation chemicals can damage product contact areas of this equipment. Elastomers (rubber components) are most likely to be affected. Always inspect all elastomer seals after passivation is completed. Replace any seals showing signs of chemical attack. Indications may include swelling, cracks, loss of elasticity or any other noticeable changes when compared with new components.

## Introduction

## Specifications

### Models

W265 FD Standard Flow Diversion Valve Assembly

W285 FD Stem Flush Flow Diversion Valve Assembly

### Sizes

1", 1-1/2", 2", 2-1/2", 3", 4"

## Features

- Flush ports
- Snap on Tef-Flow™ P Seats
- Maintainable actuators (4", 5", 6")
- Use with existing control system
- Transparent control module (*with or without solenoid*)
- S- or I-clamp connections (*S is standard*)
- Two valves with interconnected bodies
- Two-position, three-way valves with independent actuators (*air-to-raise*)
- The spring in the actuator holds the valve in the Divert position
- Air pressure positions the valve in the Forward Flow position
- Valve bodies (divert valve and leak detect valve) produce one inspection mode, and three operating modes (Divert, Flush, and Forward Flow)
- High pressure adapter for sizes 1" through 2-1/2"

### Effective Area of Actuators

4" AR = 12.12 in<sup>2</sup> (78.19 cm<sup>2</sup>)

5" AR = 19.19 in<sup>2</sup> (123.8 cm<sup>2</sup>)

6" AR = 27.50 in<sup>2</sup> (177.42 cm<sup>2</sup>)

### Air Supply Requirements

Minimum Air Pressure: 50 psi (3.4 bar) for standard springs  
75 psi (5.2 bar) for heavy-duty springs

Air Pressure Range: 50-90 psi (3.4-6.2 bar) for standard springs  
75-90 psi (5.2-6.2 bar) for heavy-duty springs

Air Volume Required: 4" AR = 12.7 in<sup>3</sup> (208.12 cm<sup>3</sup>)  
5" AR = 21.5 in<sup>3</sup> (352.32 cm<sup>3</sup>)  
6" AR = 36.1 in<sup>3</sup> (591.57 cm<sup>3</sup>)

AR = Air-to-Raise

**Callouts for Figure 1:**

1. Divert Valve
2. Leak Detect Valve
  
- A. Control Wire Connection
- B. Control Module
- C. Actuator
- D. Yoke
- E. Stem
- F. Inlet Port
- G. Divert Port (to balance tank)
- H. Leak Detect Port (to balance tank)
- I. Seat Ring
- J. Forward Flow Port
- K. Adapter
- L. Air Shutoff Valve
- M. Quick Exhaust Valve

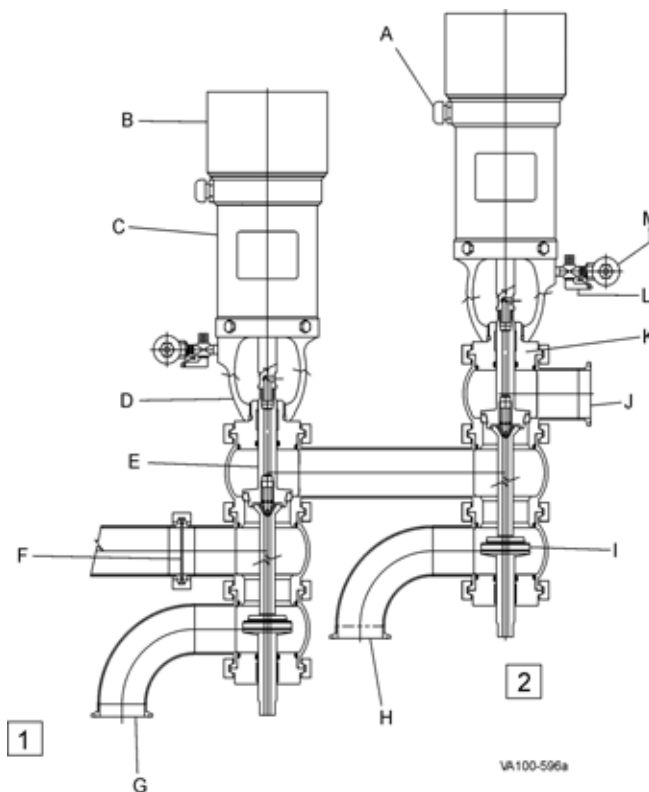

**Figure 1: Flow Diversion Valve Nomenclature**

**Callouts for Figure 2:**

- A. Micro Switch Indicator Stem
- C. Spring Retainer
- D. Spring
- E. Washer
- F. Retaining Ring
- G. Piston
- H. O-ring
- I. Quick Exhaust Valve
- J. Air Shutoff Valve
- K. Yoke
- L. Lower Actuator Stem
- M. Cap screw
- N. Bearing
- O. U-Cup Seal
- P. Cylinder
- Q. Vent Plug

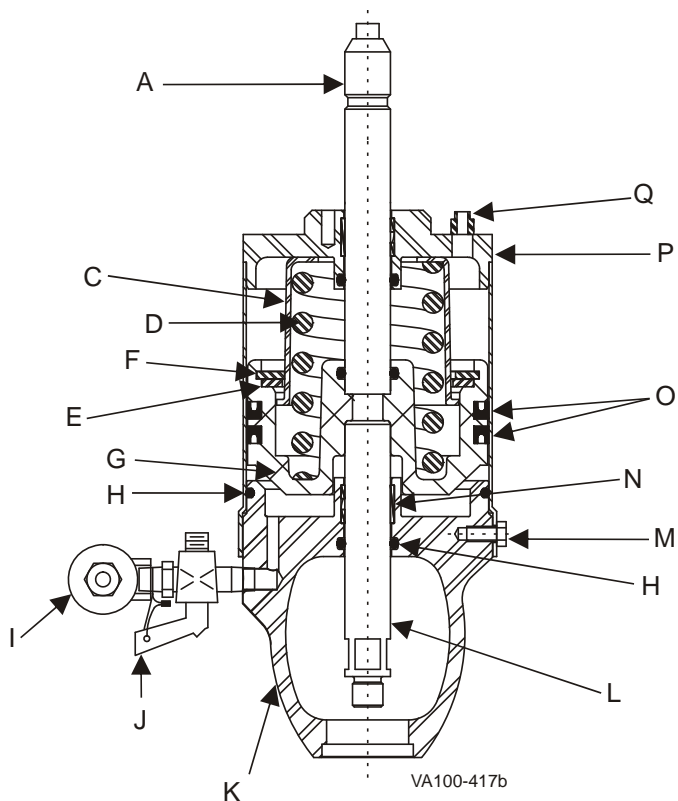

**Figure 2: Actuator Components**



# Installation

## Dimensions

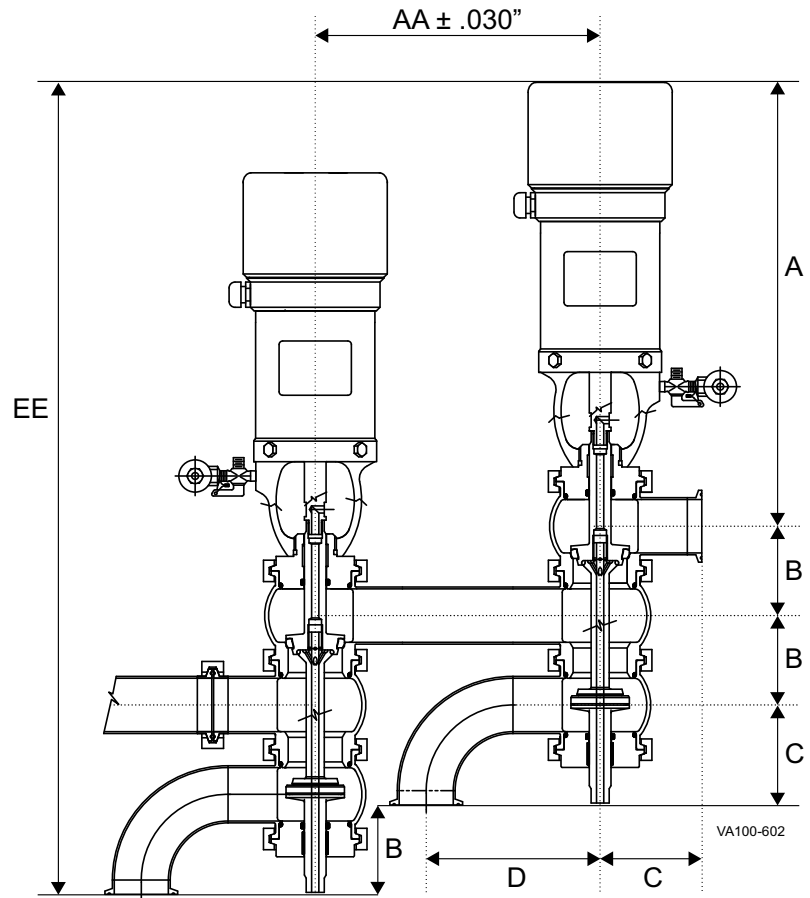

Figure 3: Valve Dimensions

Valve Size	A		A		A		B		C		C		D	
	4" Actuator		5" Actuator		6" Actuator				I-Line		S-Line			
	in	mm	in	mm	in	mm	in	mm	in	mm	in	mm	in	mm
1"	16.7	424	18.0	457	20.1	511	2.63	67	3.75	95	3.12	79	3.5	89
1-1/2"	16.7	424	18.0	457	20.1	511	2.63	67	3.19	81	2.75	70	4.5	114
2"	17.0	431	18.3	464	20.4	517	3.13	79	4.03	102	3.5	89	6.0	152
2-1/2"	-	-	18.5	470	20.6	523	3.63	92	4.16	106	3.5	89	6.8	171
3"	-	-	-	-	20.9	530	4.13	105	4.47	113	3.75	95	7.8	197
4"	-	-	-	-	21.3	542	5.11	130	5.22	132	4.5	114	9.9	251

Valve Size	Actuator		AA		EE		EE	
					I-Line		S-Line	
	in	mm	in	mm	in	mm	in	mm
1"	4	102	7.8	197	28.3	720	27.7	704
	5	127	7.8	197	29.7	753	29.0	737
	6	152	7.8	197	31.7	806	31.1	790
1-1/2"	4	102	8.8	222	27.8	706	27.3	694
	5	127	8.8	222	29.1	739	28.7	728
	6	152	8.8	222	31.2	792	30.7	781
2"	4	102	9.9	250	30.4	771	29.8	758
	5	127	9.9	250	31.7	805	31.2	791
	6	152	9.9	250	33.8	858	33.2	844
2-1/2"	5	127	11.2	285	33.6	852	32.9	836
	6	152	11.2	285	35.7	906	35.0	889
3"	6	152	12.9	327	37.7	958	37.0	940
4"	6	152	16.1	409				

VA100-706

## Control Module Routing for Compressed Air, Vent and Wiring

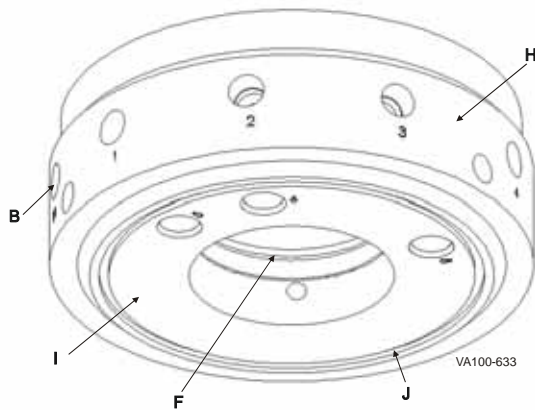

**Figure 4: Base Underside View**

- A. V-Groove Plenum with air supply channels
- B. Air-In
- C. Setscrew
- D. Vent
- E. Wire
- F. Inside Diameter
- G. Top
- H. Side
- I. Underside
- J. O-Ring
- S. Solenoid Mount

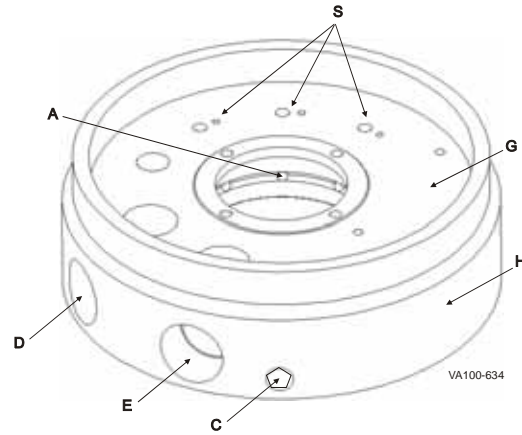

**Figure 5: Base Top View**

- A. V-Groove Plenum with air supply channels
- B. Air-In
- C. Setscrew
- D. Vent
- E. Wire
- F. Inside Diameter
- G. Top
- H. Side
- I. Underside
- J. O-Ring
- S. Solenoid Mount

Compressed air is routed through the base from **Air-In** (item B) to a V-groove air-plenum (item A) in the inside diameter (item F). Supply channels from the plenum feed each of three (3) threaded solenoid mounts (item S) on top. An energized solenoid passes air to the non-threaded outlet hole, feeding the corresponding side (item H) and underside (item I) air ports.

**For air routed to the yoke area**, i.e., W265/W285 Air-to-Raise, the underside port is plugged and the side port is open.

**For unused solenoid ports**, both the side and underside ports are plugged, and the top threaded mount is plugged.

**Vent air** from the top of the actuator is routed through the control module base via underside port no. 8. A venting plug and O-ring are used to connect the actuator port to port no. 8. Vent air passes through the module to the side vent plug (item D) in the base.

**Wiring** is routed inside the control module from the side port (item H) to the joined top port. A cable strain relief or optional pin-connector is used on the side port.

**Installation** of the top is secured using three (3) setscrews (item C) in the side of the base.

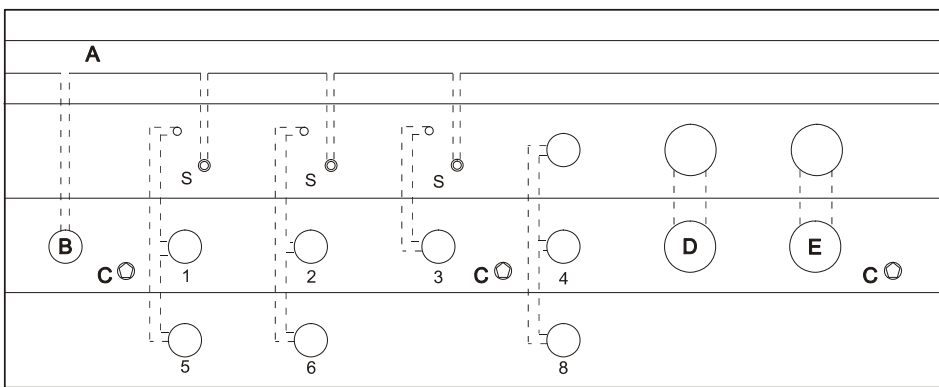

- F A. V-Groove Air Plenum
- G B. Air-In
- H C. Setscrew
- I D. Vent
- S E. Wire
- F. Inside Diameter View
- G. Top View
- H. Side View
- I. Underside View
- S. Solenoid Mount

VA100-632

**Figure 6: Routing for Compressed Air, Vent and Wiring**

## Solenoids Operation

### Barrel-Type Solenoid

- 24VDC (5-25VDC) typically used on all valves
- Typically one (1) solenoid used
- Ports in the base are numbered
- 120VAC (50-60Hz) solenoid is available

### Solenoid Operation

Solenoids direct compressed air through the ports in the base of the control module to drive the motion of the valve. For the solenoid to work correctly and achieve the required valve condition, specific ports must be open or plugged. Many configurations are possible. Figure 7 lists the appropriate configurations for W265/W285 valves. Prior to startup, perform a functional test on each valve by applying compressed air.

## W265 / W285 Single Seat Solenoid and Port Arrangements

Valve Configuration	Solenoid Location 1	Solenoid Location 2	Solenoid Location 3	Port 1	Port 2	Port 3	Port 4	Port 5	Port 6	Port 8	Top Port	In Port
Single Seat - No Solenoid - AR	Plug	Plug	Plug	Plug	Plug	Plug	Plug	Plug	Plug	Vent	Open	Plug
Single Seat - 1 Solenoid - AR	Solenoid	Plug	Plug	Open	Plug	Plug	Plug	Plug	Plug	Vent	Open	Open

VA100-648

**Note:** AR = Air to raise actuator

**Figure 7: Single Seat Solenoid Arrangements W265/W285**

**NOTE:** When the solenoid is used in the control module, a 1/4 inch diameter poly-flo tube is used to connect port 1 to the air inlet in the yoke area of the actuator.

## Control Module Wiring

Use the electrical schematic (Figure 8) for connecting control modules with or without an optional solenoid. The cable connected to the terminal block in the control modules should connect directly to the terminal block in the controller, without any splices.

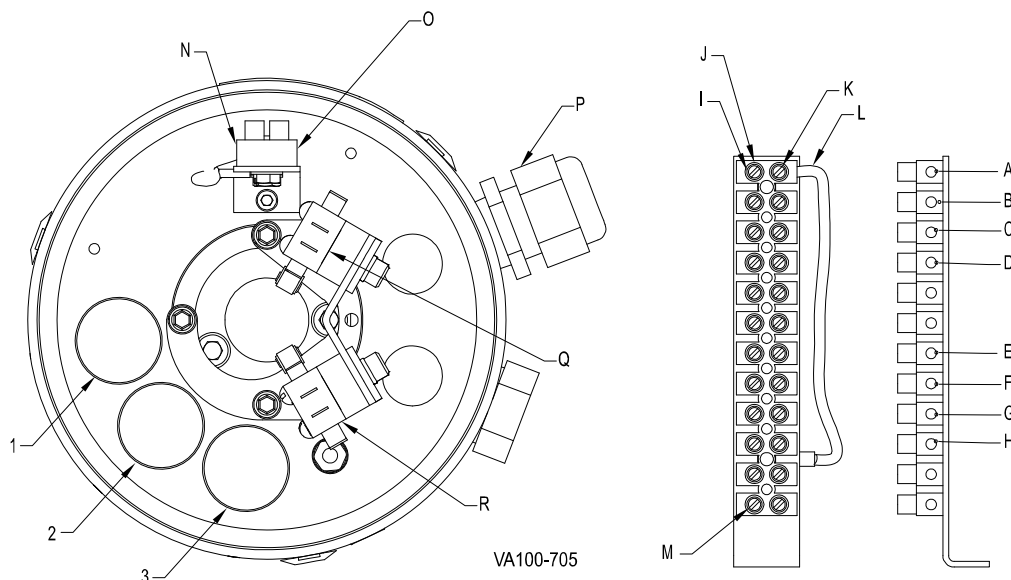

**Figure 8: Control Module Wiring**

- |                                             |                                                          |
|---------------------------------------------|----------------------------------------------------------|
| A. Ground Wire (not shown for clarity)      | M. Pole # 12 ID on this side                             |
| B. Black Wire (Switch Common; Lower, Upper) | N. Switch and Solenoid Wires this side of Terminal Block |
| C. Red Wire (Lower Switch, Normally Closed) | O. Pin Connector Wires this side of Terminal Block       |
| D. White Wire (Upper Switch, Normally Open) | P. Cable Strain Relief or Optional Pin Connector         |
| E. Black Wire (Solenoid 1,2,3)              | Q. Upper Switch (Normally Open)                          |
| F. Black Wire (Solenoid 1)                  | R. Lower Switch (Normally Closed)                        |
| G. Black Wire (Solenoid 2)                  | 1. Solenoid Location 1                                   |
| H. Black Wire (Solenoid 3)                  | 2. Solenoid Location 2                                   |
| I. Pole #1 ID on this side                  | 3. Solenoid Location 3                                   |
| J. Pin Connector Side                       |                                                          |
| K. Switch/Solenoid Side                     |                                                          |
| L. Ground Wire                              |                                                          |

**NOTE:** Use the lower switch position for the W265 Valve; use the upper switch position for the W262 Valve.

Device	Wire Color	Pole Number
Ground	Green	1
Switch Common; Lower, Upper	Black	2
Lower Switch, Normally Closed	Red	3
Upper Switch, Normally Open	White	4
Not Used	-	5
Not Used	-	6
Solenoid Common: 1, 2, 3	Black	7
Solenoid 1	Black	8
Solenoid 2	Black	9
Solenoid 3	Black	10
Not Used	-	11
Not Used	-	12

# Operation

## Operating Modes

The Flow Diversion device consists of two (2) valves. Each is a two-position, three-way valve connected by a common body. This common body is the upper body of the Divert Valve and the middle body of the Leak Detect Valve. The air-to-raise actuators of the two valves are connected to independent air supplies which cycle the valves to the three operating modes; Divert, Flush and Forward Flow. A description of the three modes follows:

### Divert Mode

Divert is the first mode of operation assumed by the Flow Diversion Valve in the start-up procedure. Until a legal product temperature is reached and normal system operation is established, the product is diverted to the Balance Tank. *In Divert Mode, the stems of both valves are in the lowered position.* This can be seen by checking the indicator stem in the control module. The roller arm of the Micro Switch, in both valves, will be positioned as shown in Figure 9, below.

The Divert Valve should be in the Divert position when:

- The control panel selector switch is in the Divert Position
- The control panel selector switch is in the "off" position.
- The power supply is interrupted.
- The air supply is interrupted.

#### Callouts for Figure 9:

1. Divert Valve
  2. Leak Detect Valve
- A. Product Inlet
  - B. To Balance Tank
  - C. Stems Lowered

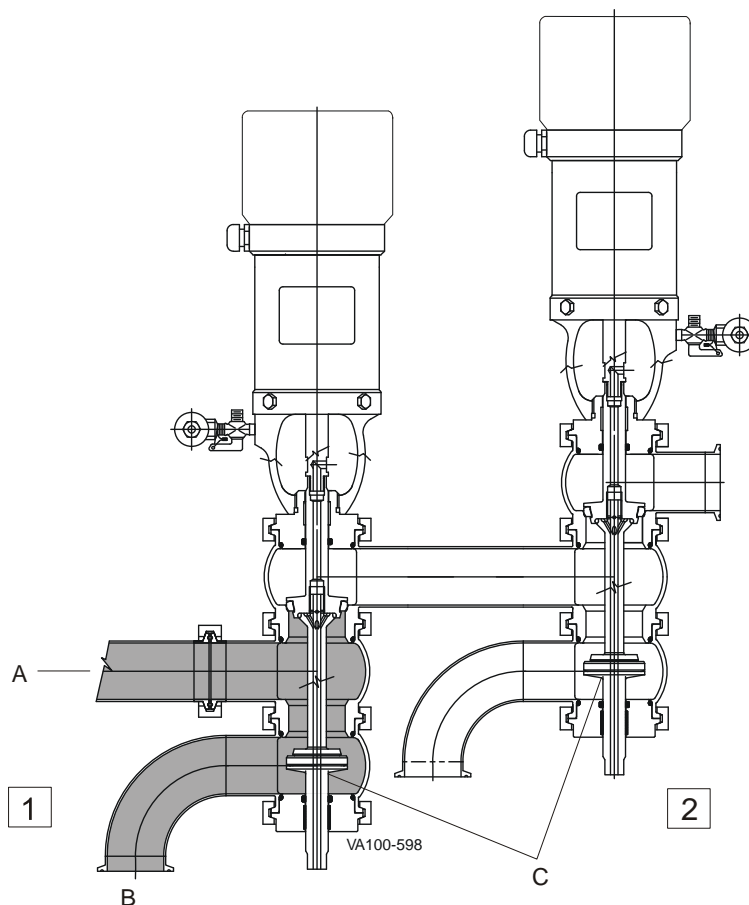

Figure 9: Divert Mode



### Flush Mode

In this mode, correctly pasteurized product flushes and clears the common body between the Divert Valves and the Leak Detect Valve, prior to initiating product Forward Flow.

The flush time is controlled by a Flow Divert Valve Controller. This control system is separate from the Divert Valves, but works in conjunction with them. **The control system can be from several sources and of several designs but must be approved by the FDA prior to use.**

Product that flows through the valves in the Flush mode is returned to the Balance Tank through the Leak Detect Valve and the Return Line. This line must be separate from the Divert Product Return Line, but both of these lines return the product to the Balance Tank.

In the Flush mode, the stem of the Divert Valve will be raised, as seen in the control module. The Leak Detect stem will be in the lowered position, which is the same as when in the Divert mode. The roller arm of the Micro Switch, in both valves, will be positioned as shown in Figure 10, below.

**Callouts for Figure 10:**

- 1. Divert Valve
- 2. Leak Detect Valve
  
- A. Product Inlet
- B. To Balance Tank

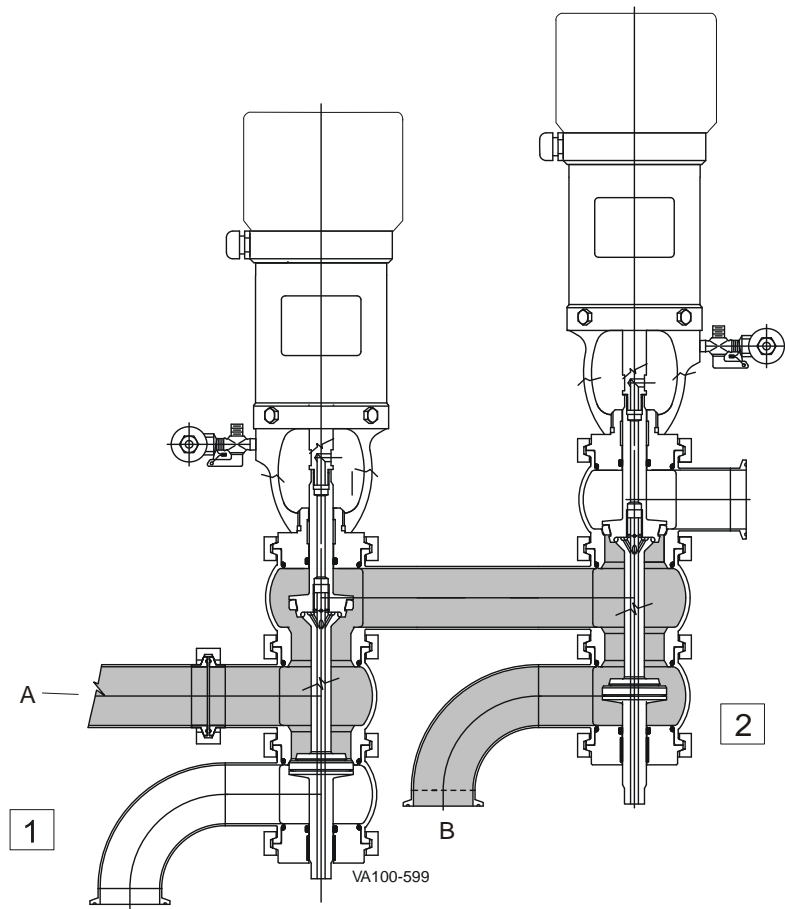

**Figure 10: Flush Mode**

### Forward Flow Mode

Forward Flow is the final operating mode of the Flow Diversion Valve. Product flows through both valves to the cooling sections of the pasteurization system. The stems of both valves are raised, as seen in the control module. In both valves, the roller arm of the Micro Switch will be positioned as shown in Figure 11, below.

For the Forward Flow mode to be maintained:

- The legal set temperature must be maintained.
- The power supply and air supply must be maintained.

#### Callouts for Figure 11:

1. Divert Valve
  2. Leak Detect Valve
- A. Product Inlet  
B. Stems Raised  
C. Forward Flow

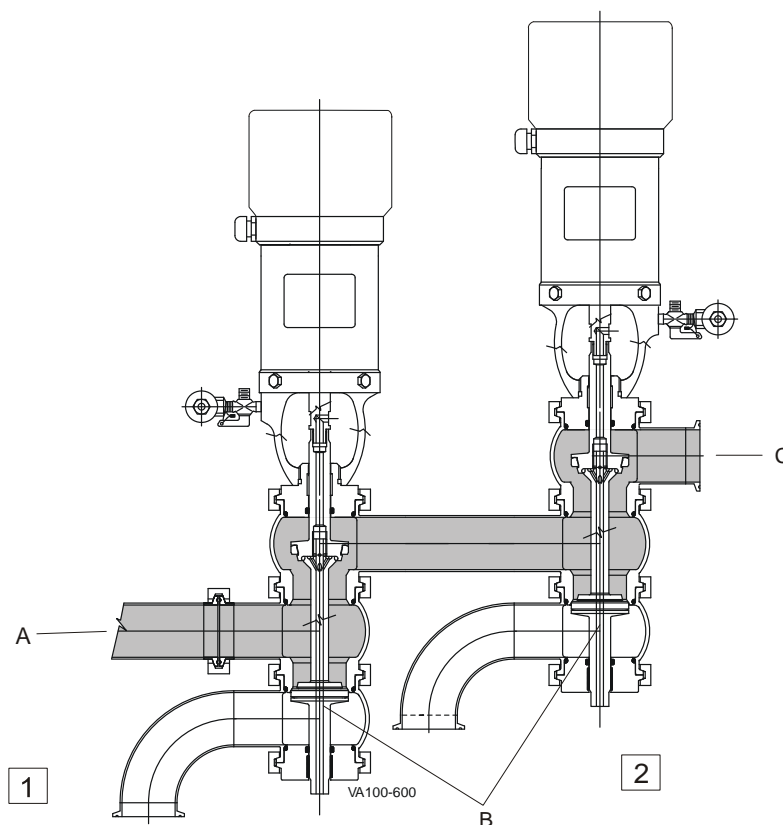

Figure 11: Forward Flow Mode

## Maintenance

### Maintenance Intervals

Maintain adequate stock of replacement parts. See the items in bold beginning on page 26 for recommended spare parts.

Maintenance intervals should be determined by the user and specific application, based on the following conditions:

- Daily operation period
- Switching frequency
- Application parameters such as temperature, pressure, and flow
- Product type

### Inspection

Inspect the following on a regular basis:

#### **⚠ DANGER**

*Do not put a hand into the yoke or body of a pneumatically actuated valve.*

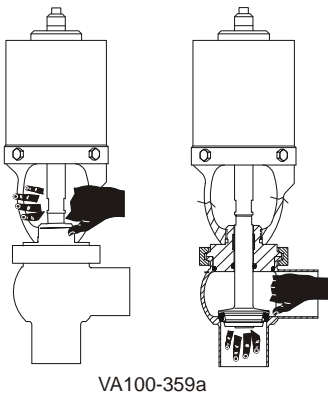

VA100-359a

- Actuator connections for air leaks
- Valve body and stem O-rings
- Valve seats (If leakage occurs, see “Troubleshooting” on page 25.)
- Pneumatic connections:
  - Air pressure at supply connection
  - Air lines for kinks and leaks
  - Threaded connections for tight fit
  - Threaded stress relief for tight fit
- Electrical connections secure on the control module:
  - Wire connections tight on the terminal strip
  - Clean air filter at regular intervals.

### Lubrication

No lubrication is required other than as noted in the disassembly and assembly procedures. (Use food grade non-petroleum (silicone) grease on seals and O-rings.)

Apply Bostik Never-Seez<sup>®</sup> White Food Grade with PTFE or equivalent to all bolts and threaded stem parts.

#### **⚠ CAUTION**

*Avoid splashing any liquid into the air vent of the actuator during clean up.*

### Cleaning

**NOTE:** *Actuate each valve a minimum of twice each cycle to ensure effective cleaning and sanitizing.*

### Cleaning-In-Place (CIP)

CIP methods can be used to clean installed automatic valves without disassembly. Select methods based on the specific requirements of sanitarians and each application. Check with local chemical suppliers for the most effective cleaning agents and procedures.



## Micro Switch

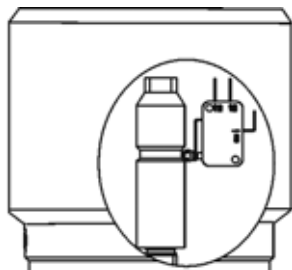

Figure 12: Micro Switch

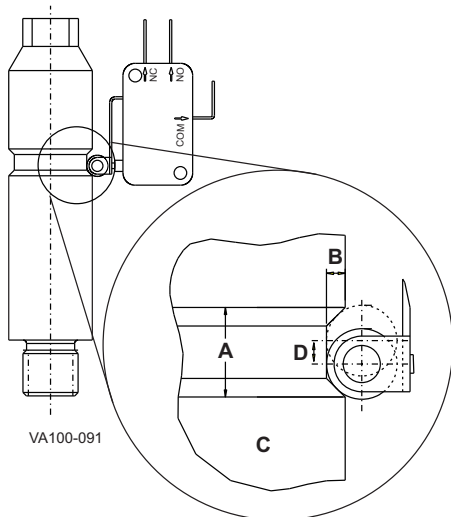

Figure 13: Detail of the Micro Switch Position for Divert Mode

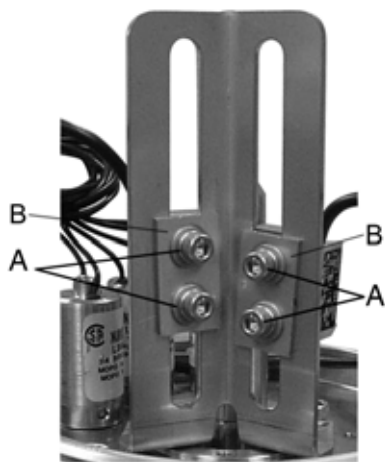

Figure 14: Control Module Detail

**NOTE:** The sensitivity of the switch is increased by moving the switch **toward** the stem and decreased by moving the switch **away** from the stem

Figure 12 shows the correct position of the Micro Switch when the valve is in Divert mode. This position allows the switch to give a signal when the valve opens and the roller moves out of the groove, and also gives an indication if the valve seat is worn excessively (the stem moves down and the roller is out of the groove).

When the roller is out of the groove, the timing pump will not start. The width of the groove in the stem is manufactured to be 1/16th inch wider than the roller to compensate for vibration and heat expansion.

**The switch roller should be positioned against the lower shoulder of the groove.**

### Callouts for Figure 13:

- A - Groove width: 0.241
- B - Groove Depth: 0.050
- C - Stem
- D - Roller Travel: 0.063  
(to allow cold flow of the Tef-Flow™ P seat ring)

### Micro Switch Adjustment

1. With the valve in Divert Position (stem lowered), adjust the switch up or down so the roller on the switch arm is in the groove against the lower shoulder on the indicator stem. Adjust the switch position using the two cap screws (Figure 14, item A) on the switch plate (Figure 14, item B).
2. Hand-tighten the cap screws to lock the switch in position.
3. Open the valve by applying air to the actuator. This will raise the stem.
4. Move the switch toward the indicator stem until the switch clicks.

**NOTE:** The position where the switch clicks or makes the circuit can be confirmed by using a volt ohm meter connected to the common and normally open contacts on the switch.

5. The correct adjustment is the point at which the switch just clicks.
6. When the adjustment point is found, tighten the cap screws to secure the position.
7. Remove the air from the actuator to lower the stem. The roller should be in the groove.

The circuit should be open when the roller is in the groove and closed when the stem is raised. If this is not the case, confirm that the roller is in the groove when the stem is down; then repeat steps 3 through 6.

## Lower Body Disassembly

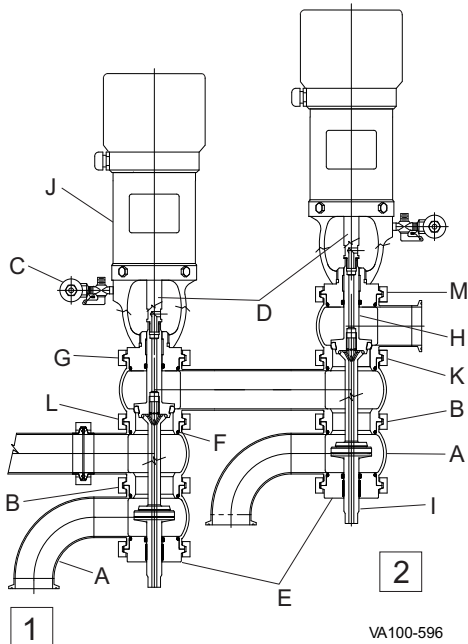

**Figure 15: Inspection and Disassembly Steps**

### Callouts for Figure 15:

- 1. Divert Valve
- 2. Leak Detect Valve
- A. Lower Body
- B. Body Clamp Connection
- C. Air Inlet
- D. Yoke
- E. Lower Bearing Retainer
- F. Body O-Ring Seal
- G. Top Adapter/Bonnet
- H. Stem, Upper
- I. Stem, Lower
- J. Actuator

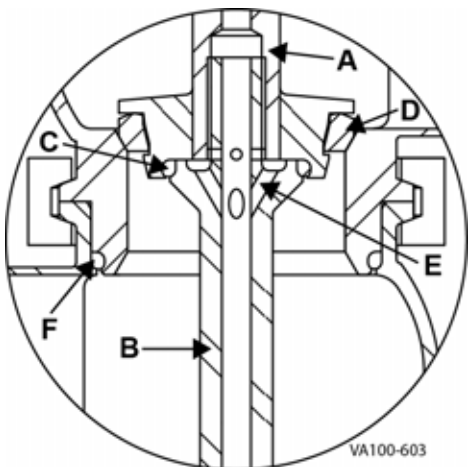

**Figure 16: Inspection and Disassembly Steps**

1. Drain the water or product from the system.
2. Disconnect the two return lines to the Balance Tank at the clamp connection on the lower body (Figure 15, item A).
3. Remove the body clamp connection (Figure 15, item B).
4. Pull the lower body down to separate it from the two upper bodies.

## Inspection

1. Inspect the body O-ring seal (Figure 15, item F) between the bottom body and the middle body. Replace it if it is damaged or worn.
2. Using two 5/8-inch open-end wrenches, unscrew the upper stem from the lower stem. Place one wrench on the upper stem just above the adapter in the yoke area (Figure 15, item D). Place the other wrench on the bottom of the lower stem (Figure 15, item I).
3. The lower stem has an O-ring in the attachment area where the two stems connect (Figure 15, item C). This should be removed and replaced with a new O-ring at each inspection interval.
4. Inspect the stem attachment area (Figure 15, Item E). If soils are present, hand-clean the upper and lower stems.
5. Inspect the seat insert (Figure 15, item D). Remove and replace if it is nicked or damaged.
6. The frequency of inspection is recommended as per Appendix I in the Pasteurized Milk Ordinance, test 5; upon installation, at least once each three (3) months thereafter; or when the regulatory seal has been broken.

**Reassemble in reverse order of the instructions above.**

## Corrective Action:

1. If leakage from the lower stem is observed during production, determine if the leakage is from the lower stem seal (item 4a on page 28) or from inside the lower stem.
2. The lower and upper valve stems are hollow to provide a clear path to the atmosphere for any leakage exiting the valve from the inside.
3. Upon disassembly, inspect for scratches, debris or damage to the stems, repair or replace as required. Replace the lower stem O-ring (Figure 16, item C). Clean all parts before reinstallation.
4. Ensure that the stems are correctly assembled.

Lubricate all O-rings with Dow<sup>®</sup> Corning #7 Silicone lubricant (or equivalent) and apply an anti-seize compound with Teflon<sup>®</sup> (for stainless steel) to all threads. The upper stem and lower stem should be tightened with 5/8-inch open-end wrenches. Do not use long wrenches or the wrench handles to tighten the stems. Over-tightening will damage the stems.

## Adapter Seal Inspection

It is necessary to completely disassemble the valve.

## Complete Disassembly

1. Disconnect the product lines, air connections, and electrical connections to the valves.
2. Open both mounting brackets.
3. Lift the valve assembly from the brackets and place it on a bench where the parts can be inspected and set aside during the disassembly process.
4. Disassemble the lower part of the valve as described in "Lower Body Disassembly" on page 18.
5. Using 5/8-inch wrench flats on the stem, unscrew and remove the lower valve stem (Figure 15, item I on page 18)

## Actuator Removal - Divert Valve

1. Remove the body clamp (Figure 15, item L on page 18) and remove the middle body of the Divert Valve.
2. Raise the valve stem on the Divert Valve by connecting an air line to the air inlet.
3. Remove the body clamp around the upper body and adapter (Figure 15, item G).
4. Remove the air supply to the actuator.
5. Remove the upper stem/adapter/actuator assembly from the upper body.
6. Unscrew and remove the upper valve stem from the actuator lower stem by using two 5/8-inch open-end wrenches in the yoke area (Figure 15, item D).
7. Inspect the O-ring and Teflon<sup>®</sup> bearing in the adapter.

## Actuator Removal - Leak Detect Valve

1. Remove the clamp (Figure 15, Item K) between the middle and upper body of the Leak Detect Valve.
2. Remove the middle body of the Leak Detect Valve.
3. Open the Leak Detect Valve by connecting pressurized air to the actuator.
4. Remove the clamp (Figure 15, item M) around the top of the upper body and adapter.
5. Remove the air pressure from the actuator.
6. Remove the upper body from the stem/adapter/actuator assembly.
7. Unscrew and remove the upper valve stem from the actuator lower stem by using two 5/8-inch open-end wrenches in the yoke area (Figure 15, item D).
8. Inspect the O-ring and Teflon<sup>®</sup> bearing in the adapter.

**Reassemble in reverse order of the instructions above.**

**CAUTION**

Remove the actuator from the valve before starting any service work on the actuator.

Lubricate all O-rings with Dow<sup>®</sup> Corning #7 Silicone lubricant (or equivalent) and apply an anti-seize compound with Teflon<sup>®</sup> (for stainless steel) to all threads. The upper stem and lower stem should be tightened with 5/8-inch open-end wrenches. Do not use long wrenches or the wrench handles to tighten the stems. Over-tightening will damage the stems.

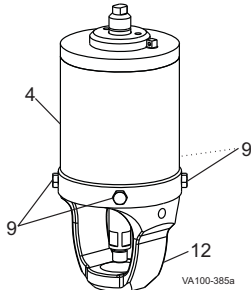

**Figure 17: Remove Yoke**

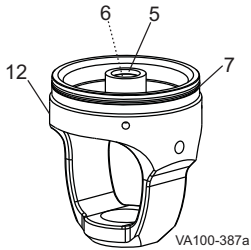

**Figure 18: Remove Yoke O-ring and Guide Bearing**

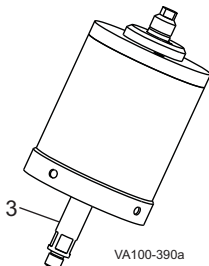

**Figure 19: Pull Lower Stem**

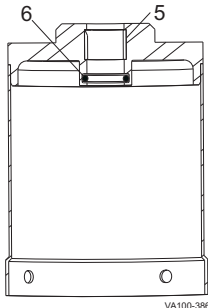

**Figure 20: Remove O-ring and Bearing**

**O-ring and Bearing Replacement: 4", 5", and 6" Actuator**

1. Remove the cap screws (Figure 17, item 9) and pull the yoke (item 12) from the actuator cylinder (item 4).
  2. Remove the yoke Figure 18 4). Inspect the lower stem O-ring (item 6) and cylinder O-ring seals (item 7).
  3. Remove the worn O-ring seals. Coat the new O-ring seals with Dow Corning<sup>®</sup> #7 Silicone Lubricant or equivalent, and replace them.
  4. Remove the PTFE guide bearing (Figure 18, item 5) by placing a screwdriver behind the bearing to pry it away from the wall of the yoke. Use needle-nose pliers to grip and remove the bearing.
  5. Pull the lower stem (Figure 19, item 3) to remove the caged spring assembly from the actuator cylinder.
- DANGER**  
 Do not use air to remove the caged spring assembly.
6. Remove and inspect the upper stem O-ring Figure 20 6) in the top of the actuator cylinder.
  7. Remove the worn O-ring seals. Coat the new O-ring seals with Dow Corning<sup>®</sup> #7 Silicone Lubricant or equivalent, and replace them.
  8. Inspect and replace the PTFE guide bearing Figure 20 5) in the actuator cylinder as needed.

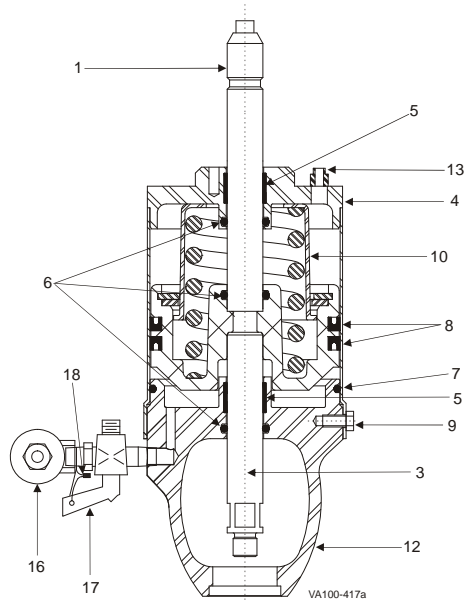

Figure 21: 4" and 5" Actuator

### U-cup Replacement: 4" and 5" Actuator

1. Inspect the piston U-cup seal (Figure 21, item 8).
2. Remove the worn U-cup seal. Do not score or nick grooves in the piston (item 10).
3. Coat the new U-cup seal with Dow Corning® #7 Silicone Lubricant or equivalent.
4. Slightly stretch the lubricated seal to fit over the piston. Install the lower seal first with the "U" pointing down. Install the upper seal with the "U" pointing up. U-cup seals flare slightly at the outer edges when they are properly installed.
5. Place the piston and spring assembly in the cylinder.
6. Place the cylinder over the yoke, and install cap screws (item 9) to secure it.

**NOTE:** If the stems were disassembled during this maintenance procedure, clean, prime, and apply Loctite® 2440 Thread Locker, according to manufacturer's specifications, to the upper (item 1) and lower (item 3) stems. Torque the stems to 200 in/lbs.

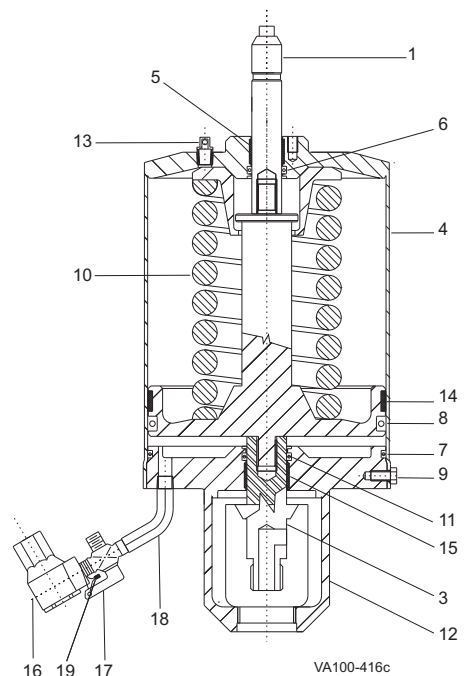

Figure 22: 6" Actuator

### O-ring and Bearing Replacement: 6" Actuator

1. Inspect the piston O-ring seal (Figure 22, item 8).
2. Remove the worn O-ring seal. Do not score or nick grooves in the piston (item 10).
3. Coat the new O-ring seal with Dow Corning® #7 Silicone Lubricant or equivalent.
4. Slightly stretch the lubricated seal to fit over the piston.
5. Inspect and replace the PTFE guide bearing (item 14) on the piston as needed.
6. Place the piston and spring assembly in the cylinder.
7. Place the cylinder over the yoke, and install cap screws (item 9) to secure it.

**NOTE:** If the stems were disassembled during this maintenance procedure, clean, prime, and apply Loctite® 2440 Thread Locker, according to manufacturer's specifications, to the upper (item 1) and lower (item 3) stems. Torque the stems to 400 in/lbs.

## Removal and Installation of Tef-Flow™ P Seat Rings

Tef-Flow™ P seats are gray and must be melted through for proper removal.

1. Melt through the seat ring using a clean plastic cutting tip on a heavy-duty soldering iron capable of maintaining a 700°F (371°C) tip temperature.

### ⚠ CAUTION

*Do not use a knife to cut the seat ring from the stem to avoid personal injury and/or damage to the stem.*

2. To install a new seat, place the installation tool base onto a table or bench with a 1.0" (25 mm) hole (Figure 23, item B). For tool part numbers, see "Installation Tools" on page 34.
3. Place the stem through the hole in the base.
4. Place a new seat ring (item C) onto the stem with the seat angle (item D) and flat side facing away from the base as shown in Figure 23.
5. Place the seat ring tool (Figure 23, item A) over the seat ring. For tool part numbers, see "Installation Tools" on page 34.
6. Using an arbor press, apply a constant steady pressure to the seat ring tool, snapping the seat ring into place.

### ⚠ CAUTION

*DO NOT use a hammer to install.*

7. The valve seat will spin freely when properly installed.

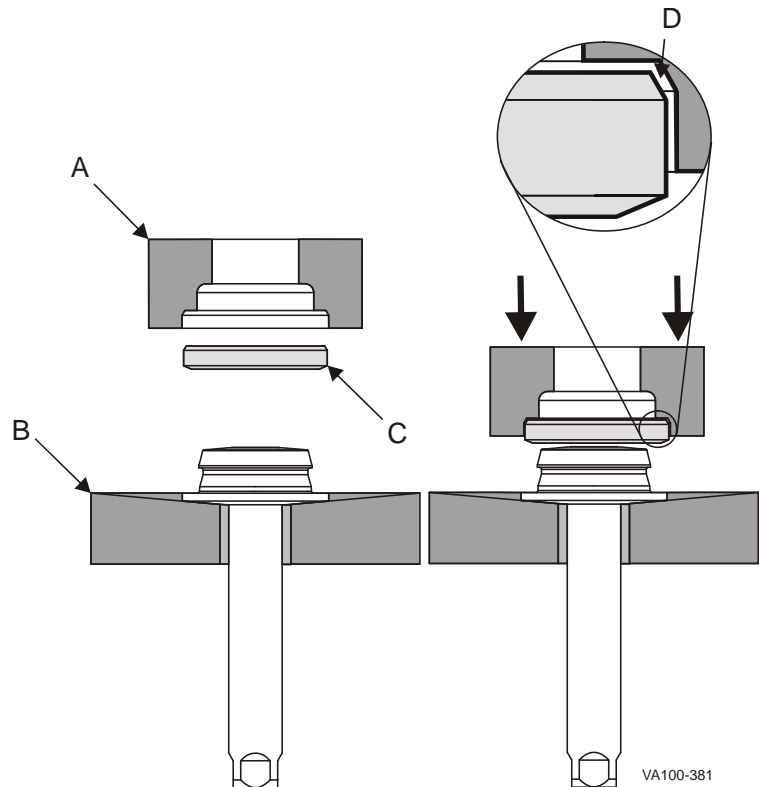

Figure 23: Tef-Flow™ P Seat

## Inspection Test Procedures

These procedures are used to check the assembly and operating condition of the Flow Diversion Device. As positive test results are obtained, attach the required **seal wire** (Figure 24, item A) in the locations specified by the procedure. Suggested corrective actions are presented at the end of each procedure in the event of test failure

### Test 1 - Device Assembled Correctly

Perform this test to verify that the Flow Diversion Device is properly assembled and adjusted. Check each valve independently, as follows, *beginning* with the Divert Valve.

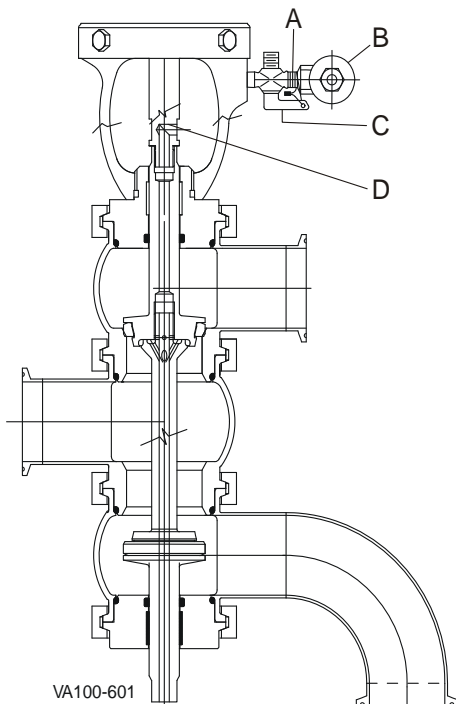

VA100-601

- A. Seal Wire
- B. Quick Exhaust Valve
- C. Air Shutoff Valve
- D. Separate Here

**Figure 24: Inspection Test Procedures**

1. With the system temperature sub-legal, set FDV Switch to INSPECT.
2. All Flow Promoting Devices (Timing Pumps) must be de-energized and stopped.
3. The Divert Valve shifts to Forward Flow position (See Figure 11 on page 15). Break the **seal wire** (Figure 24, item A) on the Air Shutoff Valve handle (Figure 24, item C). Turn the handle 90 degrees to trap air in the actuator. The actuator will remain in the raised position.
4. Set the FDV Switch to PROCESS (product/run) and the Mode Switch to AUTO. The Flow Promoting Device (Timing Pump) shall not run.
5. Set the Mode Switch to OFF. Slowly open the Air Shutoff Valve (Figure 24, item C) until the valve stem moves down approximately 1/2 inch, then close the Air Shutoff Valve.
6. Using two 5/8-inch open-end wrenches, unscrew the valve stem from the lower actuator stem about 1/8 inch (Figure 24, item D ("Separate Here")). Open the Air Shutoff Valve (item C) again. The stem will lower to the Divert position.
7. Set the Mode Switch to PROCESS. The Flow Promoting Device (Timing Pump) shall not run.
8. Repeat steps 1, 2, 3, and 4. Tighten the valve stem to lower the actuator stem, using two 5/8-inch open-end wrenches. Return the Air Shutoff Valve (Figure 24, item C) to its normally open position. Attach a new **seal wire** (item A) through the handle of the Air Shutoff Valve (item C).
9. Repeat steps 1 through 8 for the Leak Detect Valve.

**Corrective Action** - If the Flow Promoting Device (Timing Pump) fails to respond as indicated in the procedure above, immediately check the Flow Diversion Device assembly and wiring to locate and correct the cause. *Check the Micro Switch adjustment first* (see page 17). See "When the mode switch on the Flow Diversion Device is moved from Process Product to CIP, the Flow Diversion Device shall move immediately to the Divert Flow position and remain in the Divert Flow position for at least 10 minutes before starting its normal cycling in the CIP mode. Simultaneously, the booster pump shall be turned off and shall not run during the 10 minute time delay." on page 24.

## Test 2 - Time Delay Interlock with Metering Pump

**Method** - Determine that the device does not assume a manually induced Forward Flow position while the metering pump is running.

**Procedure** - With the system running in Forward Flow, move the control switch to the INSPECT position and observe that the following events automatically occur in sequence:

1. The device immediately moves to the Divert position and the metering pump is turned off.
2. The device remains in the Divert position while the metering pump is running down.
3. After the metering pump stops turning, the device assumes the Forward Flow position.
4. Repeat the above procedure by moving the control switch to the Clean-in-Place (CIP) position.
5. Record the test results and seal the control enclosure.

**Corrective Action** - If the above sequence of events does not occur, either a timer adjustment or a wiring change is required.

## Test 3 - CIP Time Delay Relay

**Application** - For all high-temperature, short-time pasteurizer systems in which it is desired to run the timing pump and/or other Flow Promoting devices during the CIP cycle.

**Frequency** - Upon installation and semi-annually thereafter, or whenever the seal on the Time Delay Relay is broken.

**Criteria** - When the mode switch on the Flow Diversion Device is moved from Process Product to CIP, the Flow Diversion Device shall move immediately to the Divert Flow position and remain in the Divert Flow position for at least 10 minutes before starting its normal cycling in the CIP mode. Simultaneously, the booster pump shall be turned off and shall not run during the 10 minute time delay.



## Troubleshooting

PROBLEM	POSSIBLE CAUSE	SUGGESTED ACTION
<b>Leakage</b>		
<b>Leakage from inside port with valve closed</b>	Seat ring failure	Replace seat rings.
	Debris trapped in valve seats	Remove valve from service. Inspect and replace seat as needed.
	Seat ring not on valve body seat	Check actuator for function.
	Stem loose	Tighten actuator stems. Tighten valve stem to actuator stem in yoke.
	Actuator loose at adapter	Remove body and stem. Tighten adapter as needed.
<b>Leakage around yoke</b>	Internal stem adapter O-ring failure	Replace O-ring.
	External body adapter O-ring failure	Replace O-ring.
<b>Operation</b>		
<b>Valve fails to open</b>	Air pressure too low	For standard spring actuators, set air pressure to 50 psi (3.4 bar). For heavy-duty spring actuators, set air pressure to 75 psi (5.2 bar).
	Control failure	Check control sequence. Check control wiring and power source.
<b>Valve fails to close</b>	Control failure	Check control sequence. Check air supply. Check for loose stems. Check control wiring and power source.
	Debris trapped in valve seat	Remove valve from service. Inspect and replace seat as needed.
<b>Actuator moves when valve opens</b>	Clamp loose	Tighten clamp with valve open.
	Yoke loose	Tighten yoke to adapter by turning actuator.
<b>Slow valve operation</b>	Air not exhausting fast enough	Install quick exhaust. Move solenoid closer to valve or install in control top.
	Valve not opening fast enough	Use a bigger diameter air line.

### Electrical

For control top/control module information, refer to the Installation section starting on page 10, as well as publication 95-03083. For additional product information, please visit our web site at [www.spxflow.com/en/waukesha-cherry-burrell/resources/product-literature](http://www.spxflow.com/en/waukesha-cherry-burrell/resources/product-literature).

# Parts Lists

## W-Series 2 Piece Control Module with Micro Switches

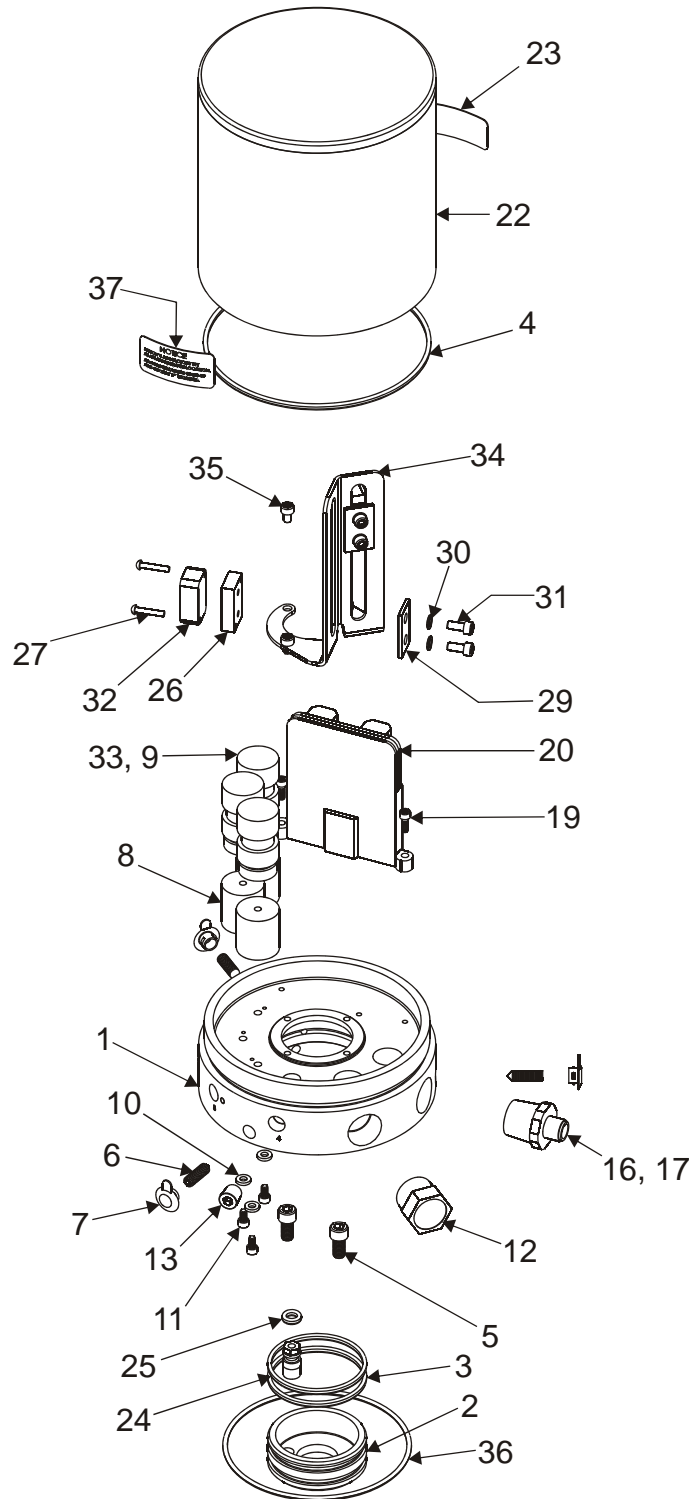

VA100-649

## W-Series 2 Piece Control Module with Micro Switches

Item #	Part Description	Part No.	Notes
1	Base - w/ effector Clipp. Solenoid Control Module	119579+	
2	Mounting Cup - Control Module	119557+	
3	O-ring	N70134	
4	O-ring	N70157	
5	SCHS - 1/4-28 x .50", 18-8 SS	119625+	
6	Set Screw - 1/4-20 x .75", 18-8 SS, Cone Point	119624+	
7	Push in Plug w/ Tab, 3/8"	121659+	
8	Booster - Solenoid Valve, Clippard	112467+	4
9	Solenoid Valve - Clippard 24VDC	112468+	
10	Washer - #6 Nylon x .062"	120067+	
11	SHCS - 6-32 x .25", 18-8 SS	119626+	
12	Breather Plug	112470+	
13	Pipe Plug - 1/8-27 NPT	78-73	
14	Nylon Washer #10	17-111	1
15	SHCS - 10-32 x .25", 18-8 SS	30-519	1
16	Pin Connector (Optional) Refer to Wiring Schematics	Varies	
17	Cable Strain Relief	17-88	
18	Terminal Block Assembly	119645+	2
19	SHCS - 6-32 x .375", 18-8 SS	119627+	3
20	Effector AS-I Slave Card (optional)	112469+	
	Device Net Card - Interlink 4 in/4 out (optional)	123648+	
22	Cover Assembly - Standard Control Module	123779+	
	Cover - Long Stroke	119562+	
23	Warning Label ("Disconnect All Power Before Removing")	5902473+	
24	Vent Plug - Control Module	119599+	
25	O-ring	N70107	
26	Switch Block	116297+	
27	Screw - #4-40 RHMS x .62	30-69	
29	Switch Plate	116296+	
30	Washer Lock, # 8, 18-8 Regular	43-20	
31	SHCS 8-32 x .375 18-8 SS	125719+	
32	Micro Switch	17-9	
33	Solenoid Valve - Numatics 120VAC	122237+	
	Solenoid Valve - Numatics 24VAC	122238+	
	Solenoid Valve - Numatics 24VDC	122239+	
34	Bracket-Micro Switch Mounting	121371+	
35	SHCS 8-32 x .25 18-8 SS	30-176	
36	O-ring	N70044	
37	Label-Switch Adjustment-Rad "Notice: Switches are factory set..."	112094+	5

PL5027-CH74

1. Not shown - used to plug hole when solenoid not used.PL5027-CH74
2. Not shown - used in place of AS-I or Device Net Card.
3. Used for both Terminal Block Assembly and Control Cards.
4. Used only with Clippard Solenoid
5. "Notice: Switches are factory set at an approximate location. Adjustment during start-up and use may be required."

### W265 / W285 FD HTST Divert Valves

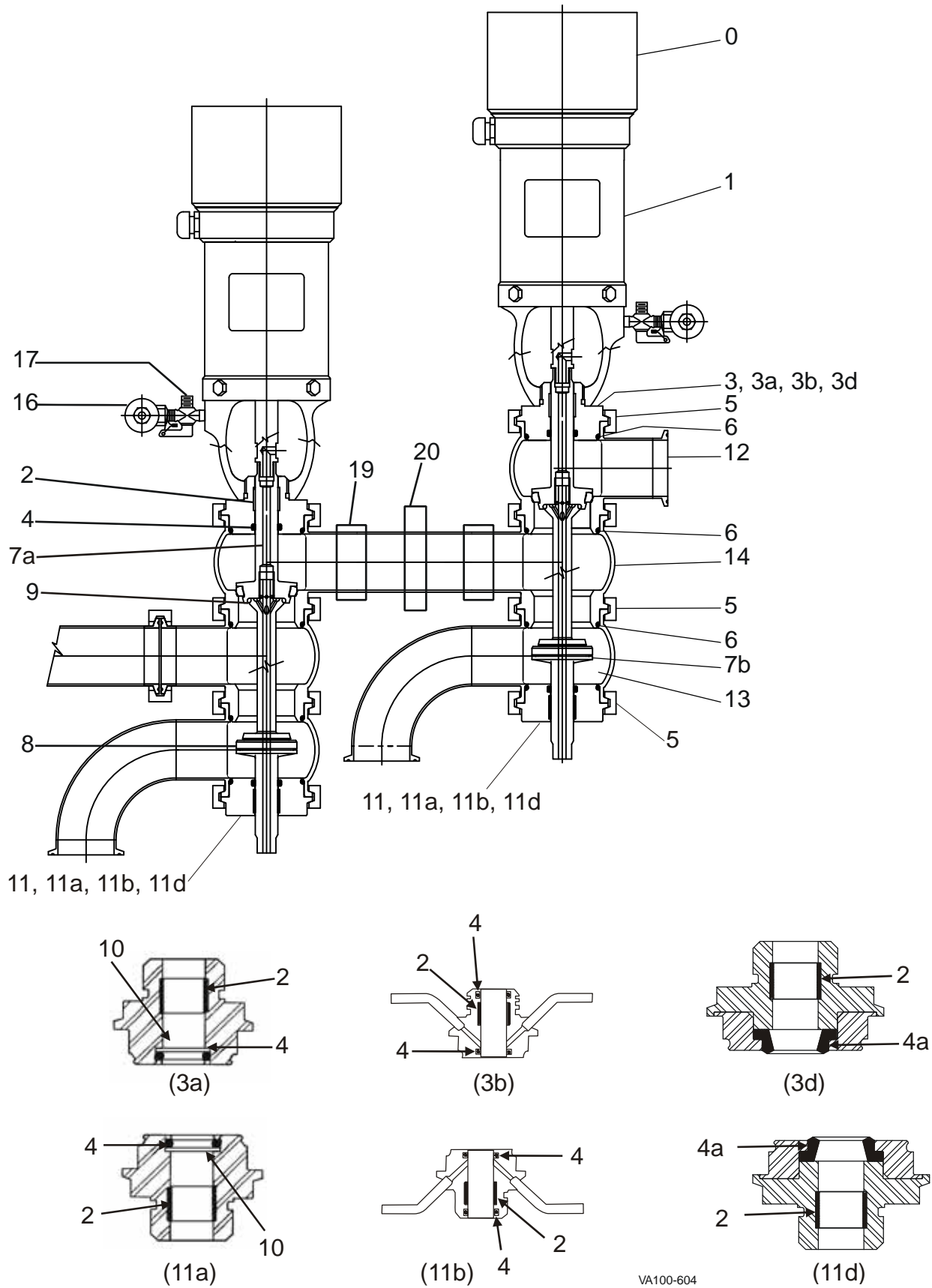

### W265 / W285 FD HTST Divert Valve

Item #	Part Description	1"	1-1/2"	2"	2-1/2"	3"	4"	Notes
0	Control Top	Contact Factory						
1	Actuator	See actuator parts list						
* 2	Bearing	102757+						
3	Adapter, Upper - W265 (Std.)	102406+		102407+	102408+	102409+	102410+	
3a	Adapter, High Pressure	W265		109293+	109294+	109295+	N/A	N/A
		W285		116925+	116926+	116927+	N/A	N/A
3b	Adapter, Upper - W285	106291+		106292+	106293+	106294+	106295+	2
3d	Adapter, Upper - Wiping Stem Seal	117879+		117880+	117881+	117882+	117883+	1
* 4	O-ring	EPDM		E70210				
		FKM		V70210				
* 4a	Wiping Stem Seal	EPDM		116183+				1
		FKM		115626+				
5	Clamp	Standard	119-30	119-33	119-34	119-51	119-87	
		High Pressure	119-271	119-272	119-273	N/A	N/A	3
* 6	O-ring, Body	EPDM	E70223	E70228	E70232	E70236	E70244	
		FKM	V70223	V70228	V70232	V70236	V70244	
* 7a	Stem, Upper (less seat ring)	Tef-Flow™	121963+	121963+	121964+	121965+	121966+	121967+
		Tri Ring	POA	128178+	127799+	124016+	128347+	128358+
		Metal	POA	POA	131663+	129233+	130984+	POA
* 7b	Stem, Lower (less seat ring)	Tef-Flow™	121974+	121975+	121976+	121977+	121978+	121979+
		Tef-Flow™ Long Stroke	N/A	N/A	N/A	125952+	125954+	125958+
		Tri Ring	POA	128179+	127800+	124018+	128349+	128360+
		Tri Ring, Long Stroke	N/A	N/A	N/A	POA	POA	POA
		Metal	106286+	106286+	131712+	129232+	130983+	POA
Metal, Long Stroke	N/A	N/A	N/A	POA	POA	POA		
8	Seat Ring	Tef-Flow™ P	115347+	115348+	115349+	115350+	115351+	
9	O-ring, Lower Stem	EPDM	E70206	E70215				
		FKM	V70206	V70215				
10	High Pressure Backup Ring	BUR210				N/A	N/A	
11	Adapter, Lower - W265 (Std.)	106329+		106240+	106241+	106242+	106243+	
11a	Adapter, Lower - High Pressure	W265	103632+	103634+	103635+	N/A	N/A	
		W285	116930+	116932+	116933+	N/A	N/A	
11b	Adapter, Lower - W285	106328+	106296+	106297+	106298+	106299+	106300+	2
11d	Adapter, Lower - Wiping Stem Seal	117979+	117980+	117981+	117982+	117983+	117984+	1
12	Body, Tee	S-Line	104167+	104171+	104175+	104179+	104183+	104187+
		I-Line	104165+	104169+	104173+	104177+	104181+	104185+
13	Body, Lower	S-Line	108851+	109313+	109314+	109315+	109316+	108852+
		I-Line	121215+	121216+	121217+	121218+	121219+	121220+
14	Body, Tee - Joined Upper/Middle	111202+	111203+	111268+	111269+	111270+	111271+	
16	Quick Exhaust Valve	5560525+						
17	Air Shut-off	5560639+						
18	Elbow Connector (not shown)	N/A		N/A	5552682+			
19	Hanger	109064+	109241+	109242+	109243+	109244+	109384+	
20	High Pressure Clamp	119-270		N/A	N/A	N/A	N/A	

PL5027-CH68

Notes:

\* Recommended Spare Parts

1. Wiping stem seal adapter and wiping stem seal options available for W265 only.
2. W285 adapter allows for liquid or steam flush of stem O-ring.
3. High pressure body clamp only required for valves equipped with high pressure adapter (item 3a).

### W265 / W285 4" and 5" Actuators

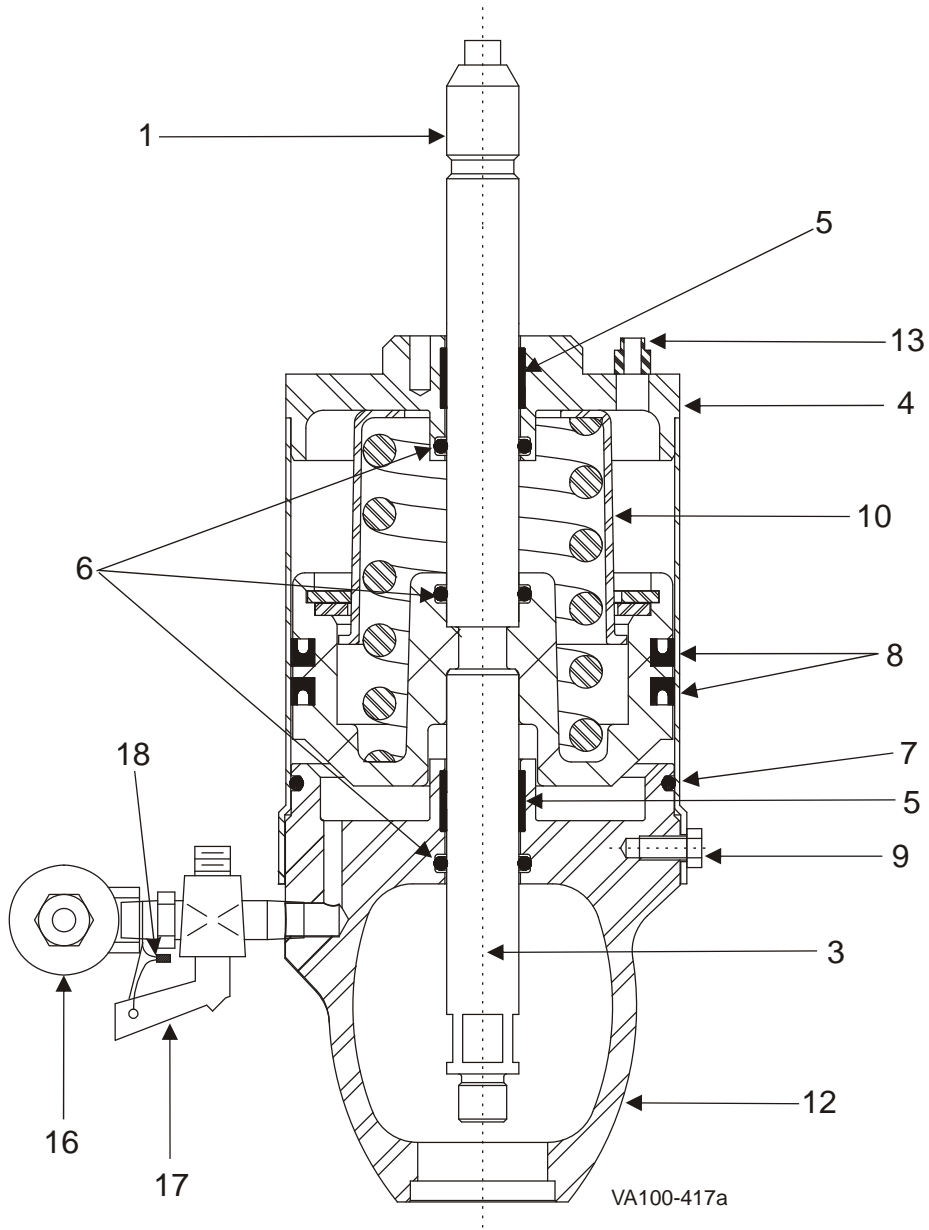



### W265 / W285 6" Actuator

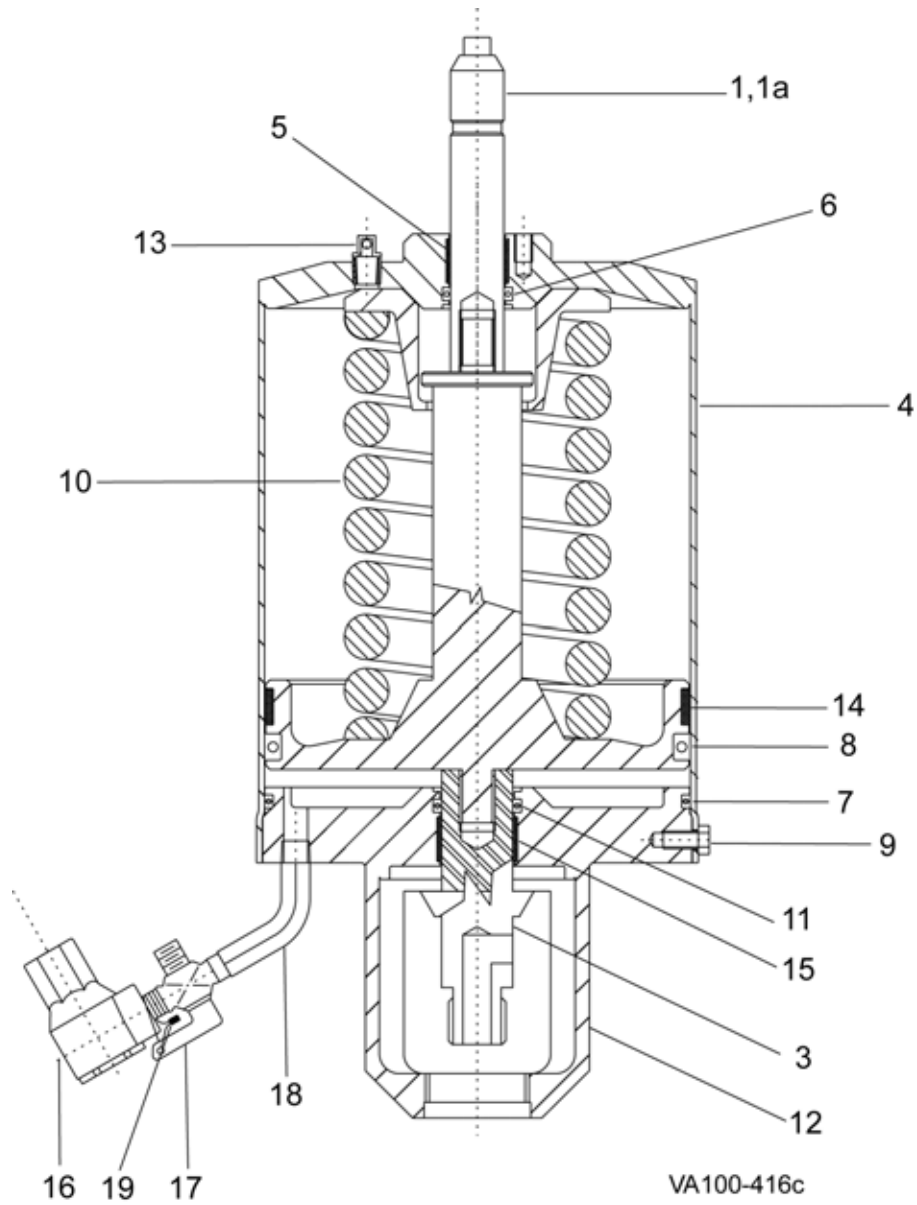





# Installation Tools

## Tef-Flow™ P Tools

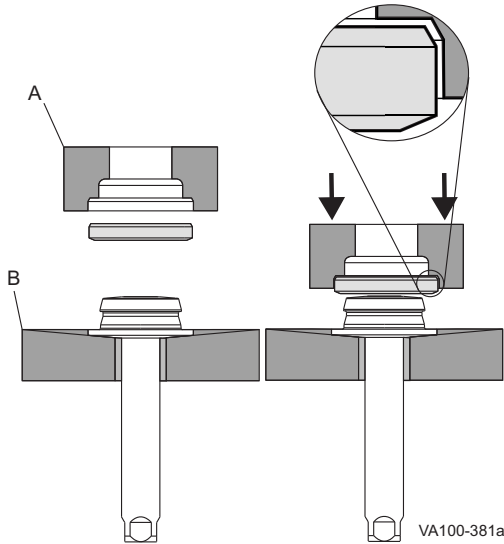

**Tef-Flow™ P Installation tools**

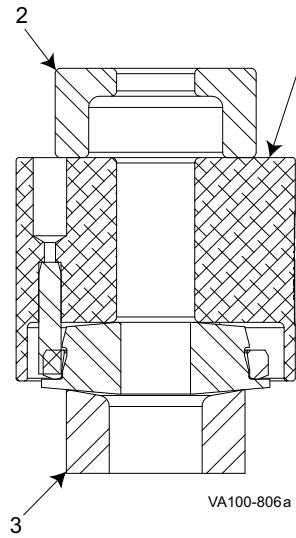

**Tef-Flow™ P Removal tools**

Tef-Flow™ P Tool Kits	Part No.	Notes
Installation Tool Kit	135036+	Includes all items listed under "Installation"
Removal Tool Kit	133470+	Includes all items listed under "Removal"

Tef-Flow™ P Tools	Valve Size					
	1"	1-1/2"	2"	2-1/2"	3"	4"
<b>Installation:</b>						
A	Seat Installation Tool	115654+	115655+	115656+	115657+	115658+
B	Install Base Tool	115653+				
<b>Removal:</b>						
1	Seat Removal Tool	133476+	133477+	133478+	133479+	133480+
2	Puck	132900+				
3	Install Base Tool, Upper Stem Insert	131301+				

PL5027-CH66d

Triplex Sales  
1-847-839-8442  
[www.triplexsales.com](http://www.triplexsales.com)





**SPX FLOW, Inc.**

611 Sugar Creek Road

Delavan, WI 53115

P: (262) 728-1900 or (800) 252-5200

F: (262) 728-4904 or (800) 252-5012

E: [wcb@spxflow.com](mailto:wcb@spxflow.com)

SPX FLOW, Inc. reserves the right to incorporate our latest design and material changes without notice or obligation.

Design features, materials of construction and dimensional data, as described in this bulletin, are provided for your information only and should not be relied upon unless confirmed in writing.

Please contact your local sales representative for product availability in your region. For more information visit [www.spxflow.com](http://www.spxflow.com).

The green ">" is a trademark of SPX FLOW, Inc.

ISSUED: 02/2020

COPYRIGHT © 2020 SPX FLOW, Inc.